



Oil King™ & Big Hauler™ Truck Drain

Waste Oil Receivers

The Oil King and Big Hauler: Large capacities and easy maneuverability provide maximum convenience and ease of use in the shop.

■ Big Hauler Truck Drain

The Big Hauler Truck Drain is a low-profile receiver designed for truck maintenance facilities. Its heavy-duty construction is rugged enough to withstand any shop condition. The Big Hauler boasts a large capacity and easy maneuverability in the shop.

- Receives all common automotive service fluids
- Heavy-duty 14 gauge metal construction
- 26 gallon capacity receiver
- Tuck-under wheels for easy movement
- Front swivel casters for maneuverability
- Fold-down handle
- Built-in baffles to reduce splashes and spills

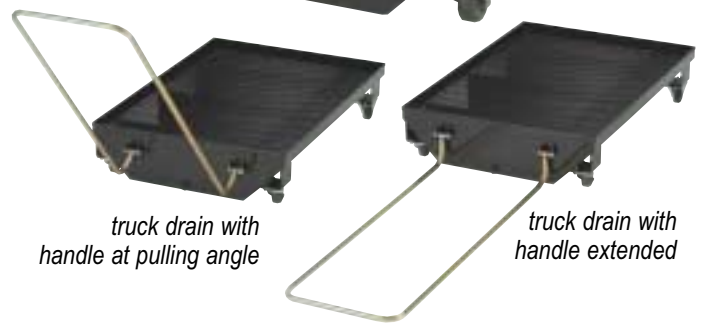
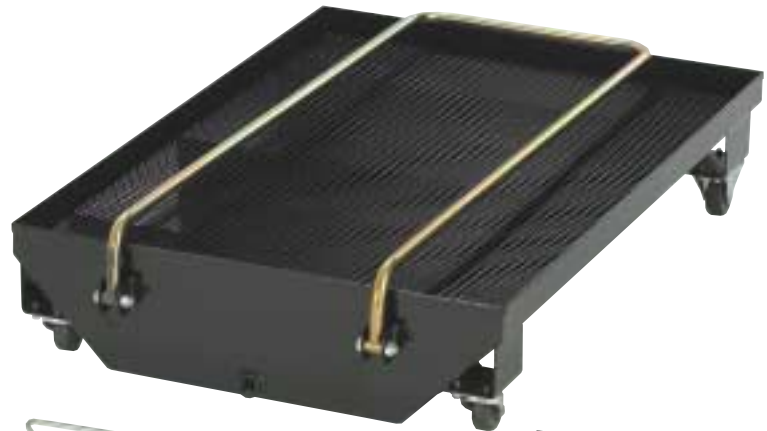

■ Oil King

The Oil King receiver is designed with the busy shop in mind. Many features make this receiver easy to maneuver around the worksite, from the oversized tires that move smoothly across uneven flooring and over hoses to the push-pull handles around the top perimeter. The funnel, which raises to a maximum height of 72 inches (183 cm), can collect fluids from both a drain plug and a filter port simultaneously.

- 25 gallon tank for high-volume use
- Oversized wheels move smoothly across uneven surfaces
- Removable filter screen prevents debris from entering the tank



Oil King Technical Specifications

Length	24 in. (610 mm)
Width	24 in. (610 mm)
Height	
with bowl at lowest adjustment	3-3/4 ft. (1143 mm)
with bowl at highest adjustment	6 ft. (1829 mm)
Dry weight	54 lbs. (24.5 kg)
Collection bowl size	22 x 24 in. (508 x 559 mm)
Inspection port size	3 in. (76 mm) thread
Fluid outlet fitting size	3/4 in. port
Operating temperature range	30-120°F (-1.11-49°C)
Maximum oil temperature	220°F (104°C)
Semi-pneumatic wheel	10 in. (254 mm)
Urethane casters	3 in. (76 mm)
Filter drain compartment capacity	6 filters
Oil capacity	25 gal. (95 l)

Truck Drain Specifications

Length	42 in. (106 x 7 mm)
Width	30 in. (76 x 2 mm)
Height	
Tank	9 in. (22 x 9 mm)
with handle in storage position	11 in. (27.9 mm)
Dry weight	85 lbs. (38.25 kg)
Collection bowl size	42 x 30 in. (106.7 x 762 mm)
Minimum ground clearance	3/4 in. (19 mm)
Fluid outlet fitting size	3/4 in. port
Operating temperature range	-40-220°F (-10-104°C)
Hard Rubber Wheels	3 in. (76 mm)
Oil capacity	26 gal. (98 l)

Oil King and Truck Drain Ordering Information

Oil King Oil Receiver	.238866
Big Hauler Truck Drain Receiver	.244055

Oil-Pumping Systems (works with either receiver)

Wall-mount 716 diaphragm pump system	.224873
Includes:	
716 Diaphragm pump	.241906
Air installation kit	.240684
Fluid installation kit	.240685
Wall bracket kit	.224835
Drum-style adapter kit	.240832
Wall-mount 1040 diaphragm pump system	.222090
Includes:	
1040 Diaphragm pump	.236265
Air installation kit	.240684
Fluid installation kit	.240685
Wall bracket accessory kit	.189233
Drum-style adapter kit	.240832
Oil King Instruction manual	308667
Truck Drain Instruction manual	309194

Sales/Distribution

North America Toll Free 800-533-9655
 Telephone 612-623-6928
 Toll Free Fax 800-533-9656
 Fax 612-378-3590
 Contact sales personnel
 Locate authorized distributors
 Product information literature



GRACO INC.
 P.O. Box 1441
 Minneapolis, MN 55440-1441



Graco Inc. is registered to I.S. EN ISO 9001.

All written and visual data contained in this document are based on the latest product information available at the time of publication. Graco reserves the right to make changes at any time without notice.